

CL24s 24 Inch LED DISPLAY

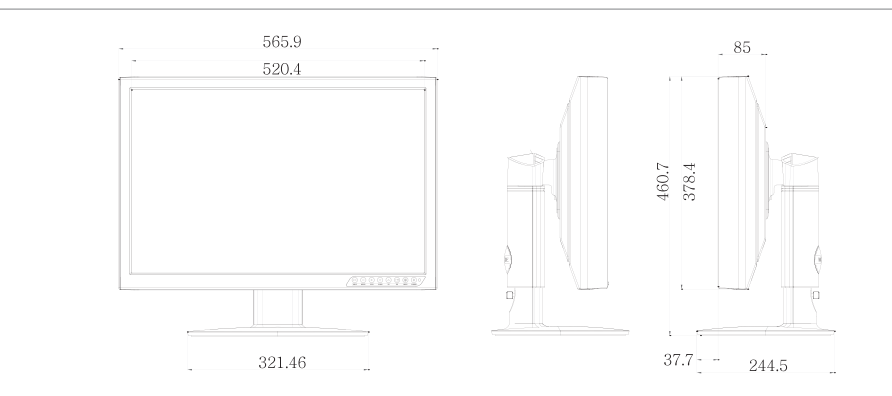

i Product dimension



i Display Performance

| | | |
|--------------------|--|----------------------------------|
| Model | CL24s | |
| LCD Panel | Description | 24.1" TFT LCD |
| | Resolution | 1920 x 1200 pixel |
| | Number of colors | 16.7 M colors |
| Visual Performance | Brightness | 300 cd/m ² (Typical) |
| | Contrast Ratio | 1000 : 1 (Typical) |
| | Viewing Angle | R/L 178°, U/D 178° where CR < 10 |
| Input Signal | 2x DVI-D | |
| | 1 x VGA | |
| | 1 x C-VIDEO | |
| | 1 x S-VIDEO | |
| External Control | RS-232C (Mini USB JACK) | |
| Power Supply | AC/DC Adaptor (AC 100-240V~, DC 24V 3.75A) | |
| Power Consumption | 60W (Max) | |
| Control Key | Power, Menu, PIP, Up, Down, Plus, Minus, Input | |
| Active Area | 518.4mm(W) X 324.0mm(H) | |
| Unit Dimension | 565.9mm(W) x 460.7mm(H) x 224.5mm(D) | |
| Weight | 9.42 kg / 20.77 lbs | |

i Environmental Consideration

| | | |
|---------------------------|----------------|---|
| Operating Conditions | Temperature | 0° ~ 40° |
| | Humidity | 5% ~ 85%, non-condensing |
| Transportation Conditions | Temperature | -20° ~ 60° |
| | Humidity | 5% ~ 95%, non-condensing |
| Storage Conditions | Temperature | -20° ~ 60° |
| | Humidity | 30% ~ 80%, non-condensing |
| Regulatory Approvals | EMC | KC : KN22, KN24, FCC Part 15 Class B, CE-EMC : EN55011, EN60601-1-2, EN61000-3-2, EN61000-3-3 |
| | ITE Safety | CB : IEC(EN)60950-1 2 _{nd} Edition |
| | Medical Safety | UL/cUL : UL60601-1, CAN/CSA-C22.2 No.601.1-M90, CB : IEC(EN)60601-1 3 _{rd} Edition |
| | CCC & CEL | GB4943.1, GB9254, GB17625.1, GB21520 |



WIDE KOREA (Gomae-Dong) 12 Wongomae-Ro, Giheung-Gu, Yongin-Si, Gyeonggi-Do 446-901, Korea Tel: +82-31-218-1600 Fax: +82-31-274-7400 info@widecorp.com **WIDE USA** 8 Hammond St., Suite #114 Irvine, CA 92618, USA Tel: +1-949-305-9933 Fax: +1-949-305-5452 info@widecorp.com **WIDE EUROPE B.V.** Panamalaan 3L, 1019 AS Amsterdam, The Netherlands Tel: +31-20-311-9797 Fax: +31-20-311-9790 infoeu@widecorp.com **WIDE JAPAN** Shinjuku Suzuki Bldg A 1-6-8 Shinjuku, Shinjuku-Ku, Tokyo 160-0022, Japan Tel: +81-3-6457-

8371 Fax: +81-3-6457-8372 infojapan@widecorp.com **WIDE ASIA** 1350/88-89, Thairong tower, Pattanakarn road, Suanluang, Bangkok 10250, Thailand Tel: +66 2 717 1843 Fax: +66 2 717 1844 infoasia@widecorp.com **Foreseeson Custom Displays, Inc.** 2210 E. Winston Road Anaheim, CA 92806 USA Tel: +1 714 300 0540 Fax: +1-714-300 0546 **Foreseeson GmbH** Industriestrasse 38a 63150 Heusenstamm, Germany Tel: +49 6104 64398 0 Fax: +49 6104 64398 11 sales@fsnmed.eu **Foreseeson UK Ltd.** Unit 2 Kingsmill Business Park Chapel Mill Road Kingston upon Thames Surrey KT1 3GZ Tel: +44 208 546 1047 Fax: +44 208 546 3931 sales@fsnmed.eu | Created in Korea. 2014. 08. ver 1.0